

BASKET STRAINER MODEL: NC57-LK

CARBON STEEL A216-WCB

NACHI

API 598

ANSI B16.34

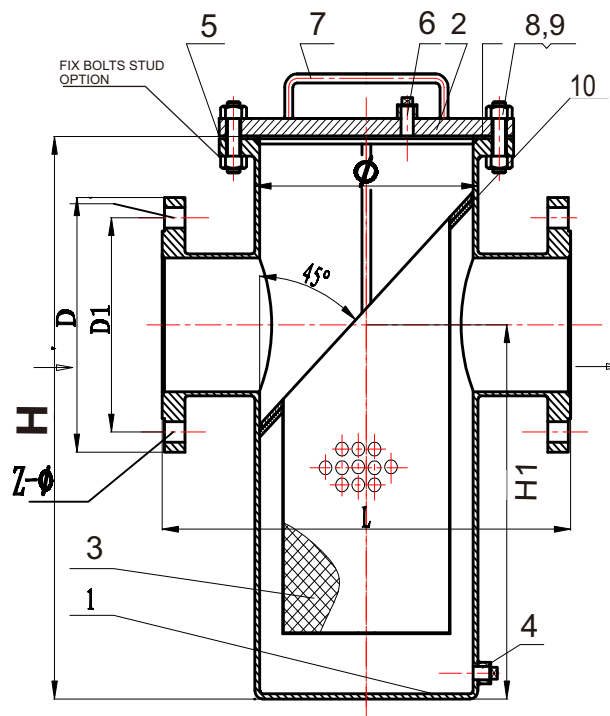

FLANGE DRILL: ANSI 150 unit.mm

DN	L	φ	H	H1	D	D1	Z-φ
25	160	76	260	160	108	79	4-16
40	260	108	300	170	127	98	4-16
50	260	108	300	170	153	121	4-19
65	330	140	360	240	178	140	4-19
80	340	159	400	250	190	152	4-19
100	400	219	470	300	216	190	8-19
150	500	273	630	420	279	241	8-23
200	560	325	780	530	342	298	8-23
250	660	420	930	640	406	362	12-25
300	750	450	1200	840	482	432	12-25
350	810	470	1370	930	533	476	12-28

note: Size dn15-dn20 use same body dimensions with dn25,different in flange dimension

www.nachivalve.com

APPLICATION:

Steam, hot oil, gas, chilled water, raw water, fluid materials where protection from foreign matter in a pipeline is required.

FEATURES

The NC57-LK strainers feature a basket with an angular cutaway design to allow straight through flow and extremely low pressure loss. All sizes have a bolted top cover flange for ease in basket removal. The gasket is a synthetic fiber and is compressed between the body and cover for maximum strength and durability. NC57-LK strainers are furnished standard with a tapped and plugged BSP drain connection.

MATERIALS SPECIFICATION

ITEM	DESCRIPTION	MATERIALS
1	BODY	CARBON STEEL ASTM A216-WCB
2	CAP/FLANGE	CARBON STEEL A216-WCB
3	SCREEN	STAINLESS STEEL AISI 304 + MESH
4	PLUG	STAINLESS STEEL ASTM A182-F304
5	GASKET	KLINGER 80 MAX.TEMP 350C TEFLON PTFE 200C
6	AIR VENT	PLUG F304-BSP
7	CAP LIFTING	STEEL ST53-7
8	BOLTS	
9	NUTS	
10	GASKET	KLINGER 80 MAX.TEMP 350C TEFLON PTFE 200C
	NOTE:	SCREEN PERFORATE 3.0mm.
	FILTER RATIO:	6:1 Free Flow Area 40%
	SIZE	1" - 20"
	OPTION	MESH 10# -100#
		DAVIT ASSEMBLY /QUICK OPENING

WORKING PRESSURE: 10BAR
FLANGE ANSI 150 /JIS 10K/ PN10
TEST PRESSURE 21.72 BAR- ANSI B16.34

STANDARD SCREEN

SIZE	HOLE DIAMETER	FREE FLOW AREA
DN25-80	1.5mm	33%
DN100-600	3.0mm	40%

DRAWING AND DIMENSIONS:

FLANGE DRILL: ANSI 150 -ANSI B16.5 FACE TO FACE DIMENSION: MANUFACTURE'S STD

price@nachivalve.com		www.nachivalve.com	
NACHI VALVE CO.LTD			